

Home Theater

What is Home Theater?

Since the mid- to late-1990s, home theater systems have rapidly grown in popularity, as consumers have looked for ways to enjoy movies at home the same way they do in traditional movie theaters. With the advent of DVD and Blu-ray players, having true at-home theater-quality sound and video has now become a reality. This technical article will help explain what a home theater is and how it can be set up.

So what exactly is home theater? A home theater system enables you to reproduce the sound and video quality of a commercial movie theater in your own living room. Prices for home theater systems can be as low as a few hundred dollars or up into the tens of thousands of dollars. Fortunately, creating a home theater of your own requires only a few components. A basic home theater system consists of a television, a DVD or Blu-ray player, an A/V receiver that supports surround sound, and five speakers.

What do you need for a Home Theater system?

What devices/components are needed for a home theater system? The most basic components for a home theater system would consist of a video display (a standard TV, a plasma or LCD TV, a projector, etc), a surround sound A/V receiver, and a video source (DVD or Blu-ray player, cable or satellite box). When creating more elaborate home. When it comes to how many speakers? What kind of speakers? There are many different options. The most basic setup would have five speakers: 2 front speakers (left and right), a center channel, and 2 rear speakers (left and right). Higher end speaker setups would consist of up to 9 speakers: 2 front speakers (left and right), a center channel, 2 mid-rear speakers (left and right), 2 rear speakers (left and right), a center rear channel, and a subwoofer.

How do I hook up a Home Theater system?

Hooking up a Home Theater system is a lot easier than it sounds. The fundamental rule when connecting the components together is that all the cables are connected, OUT to IN. The sound or the video signal will transfer OUT of a device, a DVD or Blu-ray player, CD player, VCR etc., and IN to another, surround sound receiver or a video display. How you hook up your system will depend on the selection of inputs/outputs your device has. Here are some diagrams on how to connect the components together.

Diagram 1:

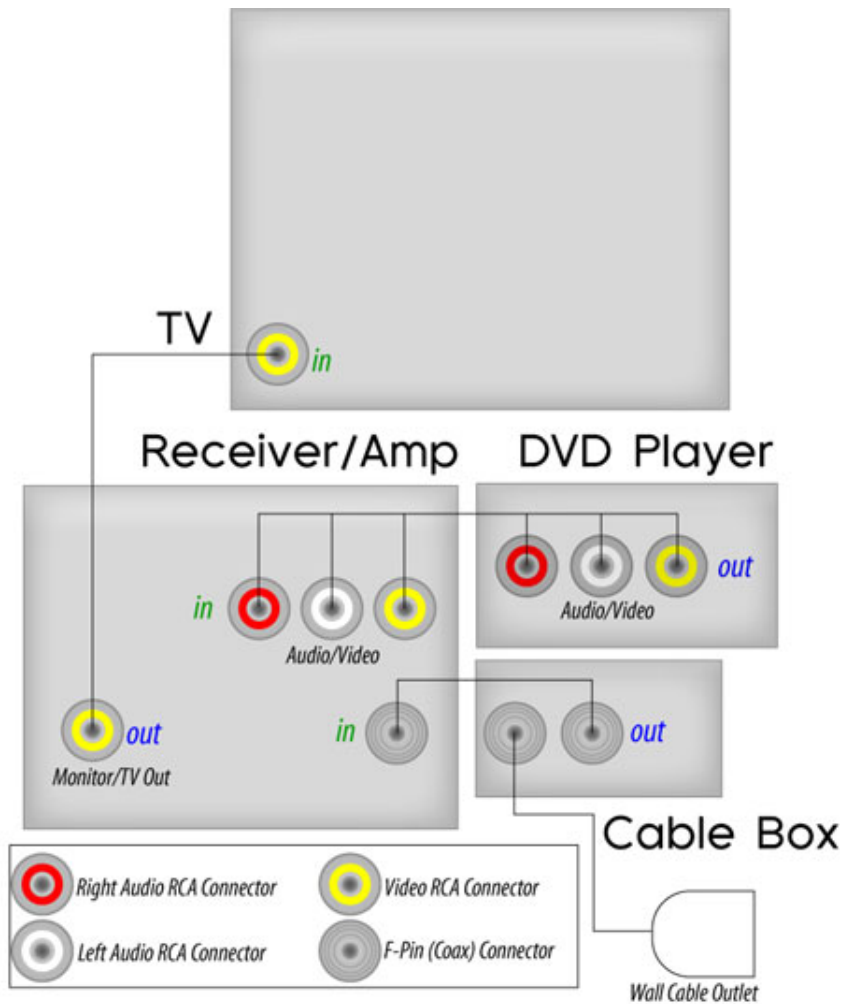

Diagram 1 illustrates a simple home theater configuration consisting of a TV, cable box, DVD player and a receiver/amp.

With this setup the connections between the DVD player, TV and the receiver/amp are all using [Red, White and Yellow RCA cables](#).

Cable TV and DVD movies will all be outputted in analog surround sound, known in the industry as Dolby Pro-Logic (See glossary for a description).

This setup will enable you to view both video sources, Cable TV and DVD on a single input on the TV by selecting on the receiver/amp which signal you want to watch. When selecting an input source, DVD or cable box in this diagram, the video signal will be passed through the receiver/amp and will output through the monitor/TV out (See glossary for a description) connection to the TV.

All of the audio, the red and white RCA connections, will be outputted to the speakers via [speaker wire](#).

Diagram 2:

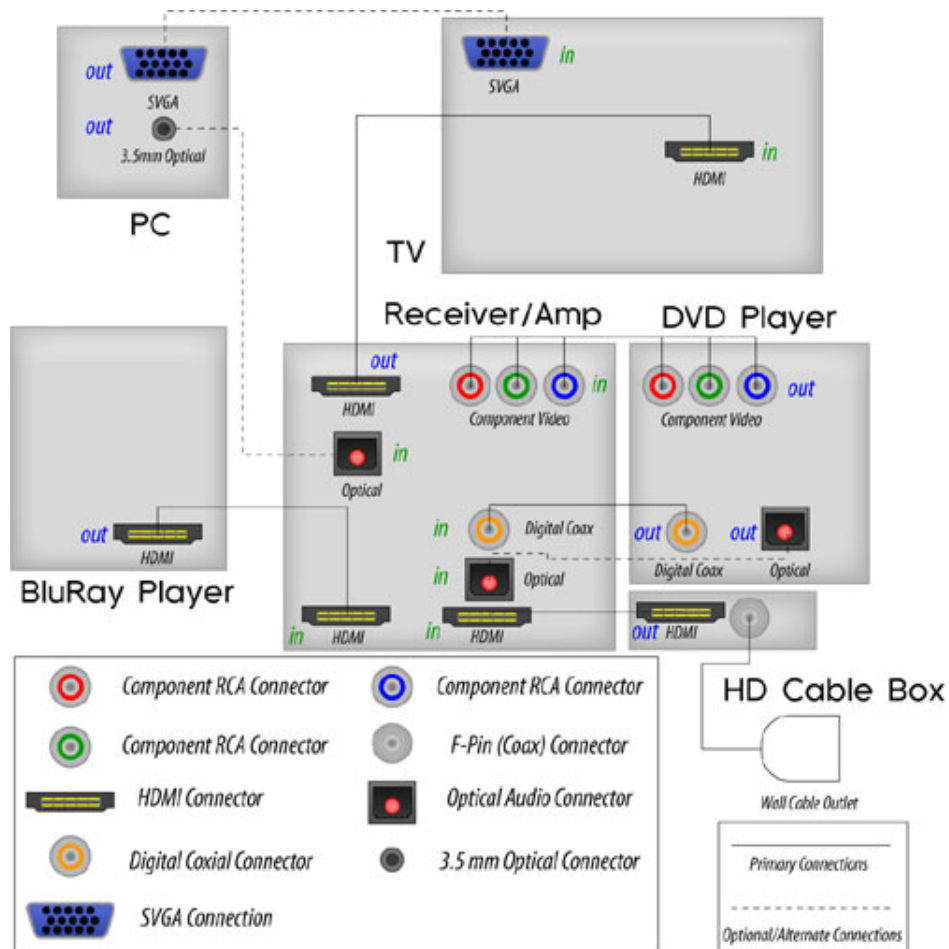

Diagram 2 illustrates a more complex home theater configuration consisting of a high definition TV, a DVD player, an HD satellite box, a Blu-ray player, a desktop computer and a receiver/amp.

With this setup the DVD player, Blu-ray and satellite box all connect to the receiver/amp. The DVD player connects via [component \(red, green, blue RCA cables\)](#) while the satellite box and the Blu-ray connect via HDMI cables.

The computer uses a [VGA cable](#) to go from the video card into the TV, and uses a [3.5mm optical to toslink optical cable](#) to connect to the receiver/amp for high quality digital surround sound. (Please note: 3.5mm optical is a fiber optic connection and it is not compatible with standard 3.5mm analog commonly used in headphones)

The DVD player connects to the amp with a digital coax cable. All 4 audio sources will then be outputted in Dolby Digital surround sound (See glossary for a description).

The receiver/amp outputs video to the TV via an HDMI cable.

This setup will enable you to view satellite TV and DVD/Blu-ray video on a single input on the TV. To view the computer, the input will have to be switched to the VGA input on the TV.

DVD players will usually have 3 different video outputs: Composite video (Yellow RCA), [S-Video](#), and Component video. They also have 3 different audio outputs: RCA (Red and White RCA's, Analog), [Optical \(Digital\)](#) and Coax (Digital - Optional). Blu-ray players can have HDMI, component and s-video, with RCA, optical or [digital coax](#) for additional audio. In this diagram the DVD player uses component plus optical for optimal audio/video, while the Blu-ray uses a single [HDMI cable](#) as HDMI carries audio and video in the highest possible quality.

How do I connect the Speakers in a Home Theater system?

Connecting the speakers in a Home theater system is very easy, much easier than hooking up the components. Speaker wire will consist of one cable with two separate wires: positive and negative. The wires can be striped apart and are labeled either positive or negative. The gauge (AWG) of the wire will determine the quality and performance of the sound output. The thicker the wire is the lower the gauge will be. The following diagrams illustrate ideal placement and how to connect the speakers to the Receiver/Amp.

Diagram 3:

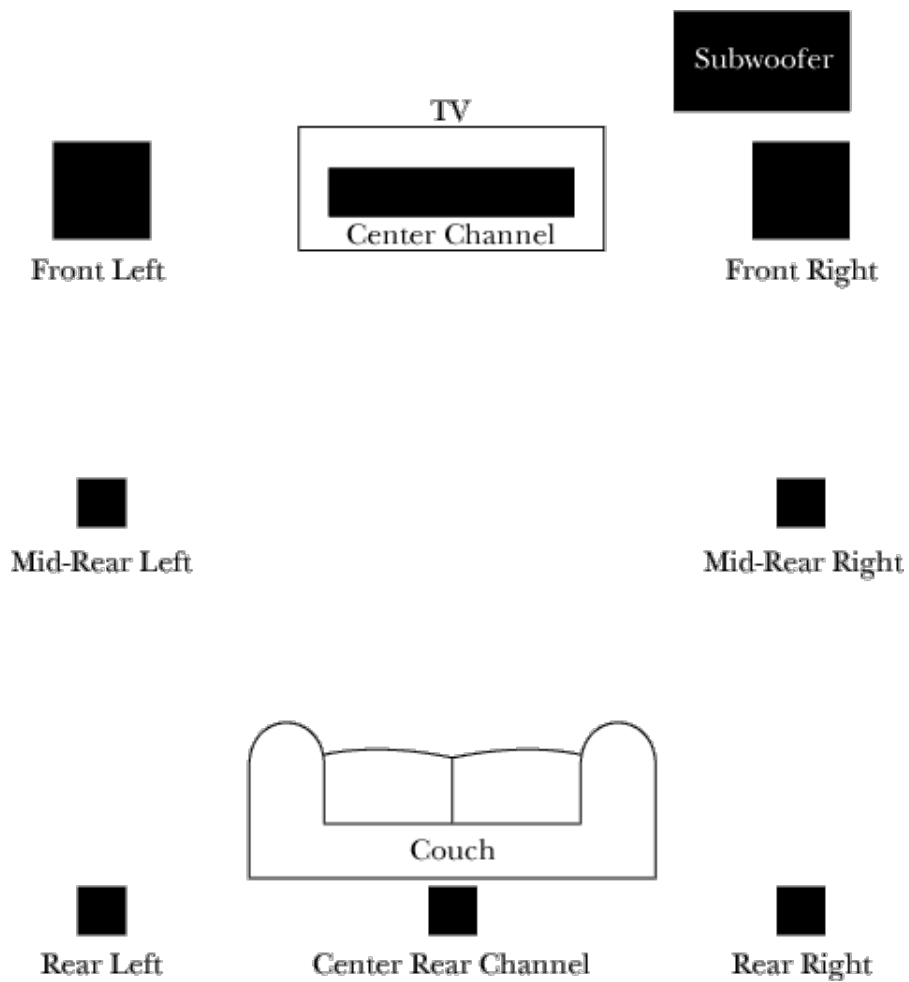

Diagram 3 illustrates ideal positioning of speakers in a Home theater system.

Diagram 4:

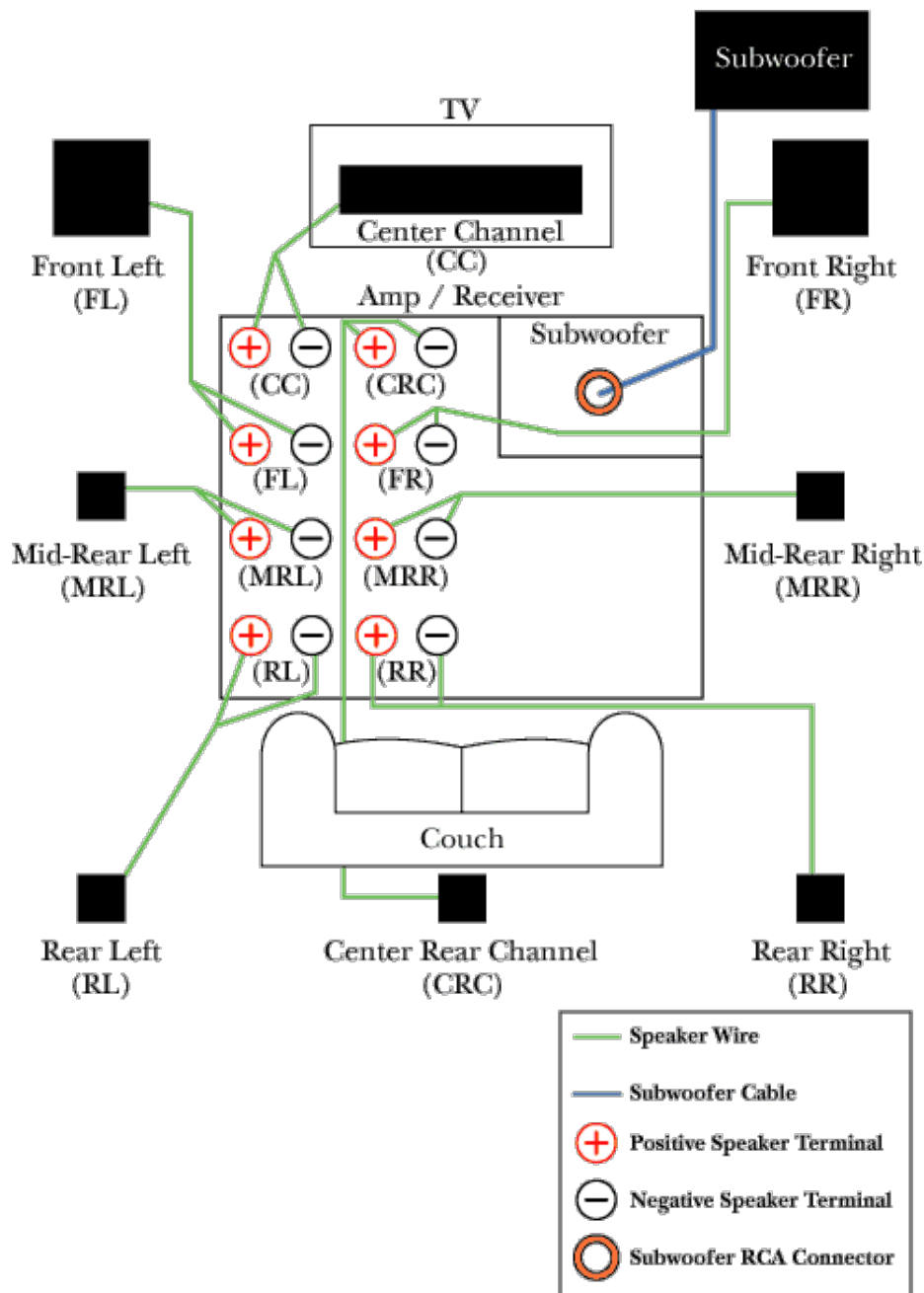

Diagram 4 illustrates the connections between the speakers and the receiver/amp. The same layout from Diagram 3 is being used as the model. All speakers require a positive and negative connection for them to work as you can see above. Primarily the Subwoofer will connect using an RCA cable, the reason for this, is that a powered Subwoofer will have an amplifier built into the unit. Due to the amplifier being in the Subwoofer the amplification is done there, therefore the signal from the receiver/amp would be a line level signal (See glossary for a description).

Glossary of Industry Terms

5.1 Surround Sound - See Dolby Digital (AC-3) and DTS (Digital Theater Sound). From Diagram 4 it would incorporate speakers: FR, CC, FL, RR, RL and the Subwoofer.

6.1 Surround Sound - This sound field is used with new media such as THX Surround EX and DTS-ES 6.1 Matrix. It utilizes a rear speaker that is located directly behind the seating area (CRC). From Diagram 4 it would incorporate speakers: FR, CC, FL, RR, CRC, RL and the Subwoofer.

7.1 Surround Sound - This is typically a receiver/amp manufacturer's proprietary surround sound field to fill in the two new back surround channel speakers. From Diagram 4 it would incorporate speakers: FR, CC, FL, MRR, MRL, RR, RL and the Subwoofer.

Dolby Pro-Logic - This is the surround sound "standard" format from the 1990's. It is still used today for VCR's and standard Cable TV due to the limitation that they can only output analog. It consists of five speakers plus a subwoofer, however, only has three discrete channels: Front Left, Front Right and both rears acting as one channel. The center channel output the combined audio from the Front Left and Front Right speakers.

Dolby Digital (AC-3) - Dolby Digital is a 5.1 surround sound setup. It consists of five discrete speakers (5) plus a subwoofer (.1).

The ".1" from 5.1 is a certain LFE (Low Frequency Effects) signal designed for a powered subwoofer which will deliver the thump and the boom from movies. A complete Dolby Digital signal outputs a frequency range of 20Hz to 20,000Hz, the subwoofer will output only 20Hz to 120Hz.

DTS (Digital Theater Sound) - Another digital surround sound format, similar to Dolby Digital. It is a competing format to Dolby Digital which was released about a year after. DTS (Digital Theater System) is a 5.1 surround sound setup. It consists of five discrete speakers (5) plus a subwoofer (.1). The ".1" from 5.1 is a certain LFE (Low Frequency Effects) signal designed for a powered subwoofer which will deliver the thump and the boom from movies. A complete Dolby Digital signal outputs a frequency range of 20Hz to 20,000Hz, the subwoofer will output only 20Hz to 120Hz.

HDMI - HDMI cables, also known as High-Definition Multimedia Interface, not only transmit video, but audio as well. HDMI is the next generation for connecting audio/video devices together. HDMI cables are used with high definition devices such as blu-ray players and game systems.

Optical - Optical cables use a beam of light to transmit high quality sound with nearly zero quality loss.

Digital Coax - Digital coax uses an RCA cable to transmit high quality digital surround sound.

Component Video - Component video is a newer way to connect video devices together, typically used with DVD Players, HDTV set-top converters, and even some games systems. It utilizes three separate RCA connections which transmit in an RGB (Red, Green and Blue) format. It will deliver the highest picture quality from an analog source.

Composite Video - This is the most basic connection between video devices. It is used with DVD Players, VCR's, TV's, Cable Boxes, etc... It consists of a single "Yellow" RCA cable.

Line Level Signal - A non-amplified signal usually connecting a receiver/amp to the Powered Subwoofer. This signal is transmitted using an RCA cable.

Low Frequency Effects (LFE) - This refers to the low frequencies that a subwoofer will play from many movies, typically a range of 20Hz - 120Hz. In a digital surround sound environment it will deliver the ".1" that you would see from 5.1, 6.1 etc... When you see an explosion in a movie the speakers will allow you to hear it but the subwoofer, outputting the LFE's, will allow you to "feel" it.

Monitor/TV Out - The video output from the receiver/amp directly to the TV. This connection will output the video signal from the source that has been selected on the receiver/amp. The Monitor/TV Out are Composite Video, S-Video or Component Video outputs.

S-Video - This connection outputs a high picture quality from DVD's, SVHS VCR's, Digital Satellite Boxes, Digital Camcorders, etc. S-Video is a much higher quality format when compared to composite video, but is becoming obsolete with the popularity of component and HDMI video.