

# Product Specifications

REV.	DESCRIPTION	DATE
A		
B		07-2010

## Construction & Material :

Item		Specification
Product		RG 58U, Solid Coaxial Cable
Conductor	Construction	Solid 20AWG
	Material	Bare Copper
Insulation	Material	PE
	Avg.thickness	1.07 mm
	Diameter	2.95 ± 0.05 mm
Braid	Construction	0.11mm*32
	Material	Bare Copper
	Covering	43.5%
Jacket	Material	PVC
	Avg.thickness	0.712 mm
	Diameter	4.95 ± 0.10 mm
	Color	Black

RoHS

## Cross Section:

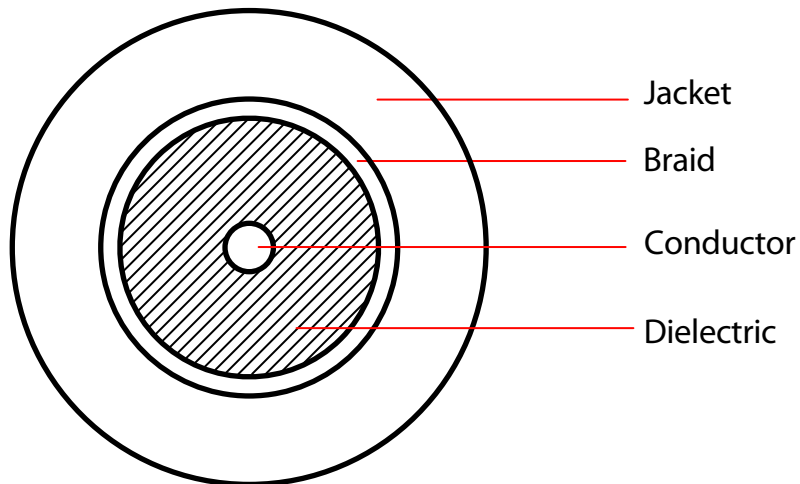

Characteristics			
Sparker Test:	2500VAC		
Dielectric Strength:	Conductor to Shield : 3 Sec. @ 2500 VDC		
Impedance:	50±3 Ohm	DRAWER	LIBRA
Capacitance:	28.5+3pF/Ft (Nom.)	CHECKED	
Velocity of Propagation	80%	APPROVED	
DCR:	Conductor: 7.60 ohms/1000ft Shield: 4.90 Ohms/1000ft		
PART NUMBER:	TITLE:	 888-212-8295	
10X1-022NH	RG58U 20AWG, Solid, Braided Coaxial Cable, Black, 1000 ft, Spool		